

# TOSHIBA

Leading Innovation >>>

## AIR CONDITIONER (SPLIT TYPE) Installation manual



### Outdoor Unit

Model name:

---

RAV-SM2244AT7

RAV-SM2244AT7Z

RAV-SM2244AT7ZG

RAV-SM2244AT8-E

RAV-SM2244AT8Z-E

RAV-SM2244AT8ZG-E

RAV-SM2804AT7

RAV-SM2804AT7Z

RAV-SM2804AT7ZG

RAV-SM2804AT8-E

RAV-SM2804AT8Z-E

RAV-SM2804AT8ZG-E

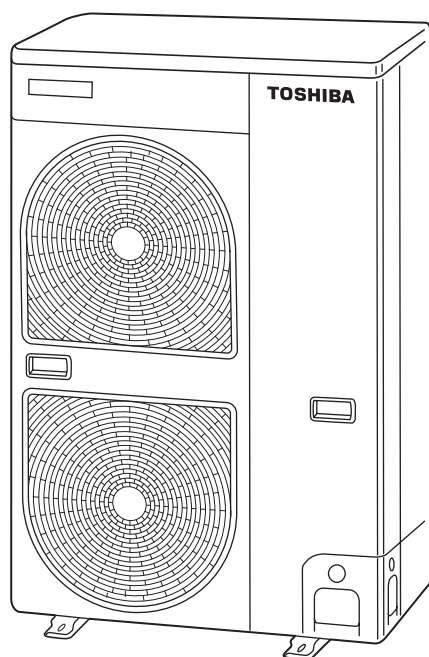

Please read this Installation Manual carefully before installing the Air Conditioner.

- This Manual describes the installation method of the outdoor unit.
- For installation of the indoor unit, follow the Installation Manual attached to the indoor unit.

### ADOPTION OF NEW REFRIGERANT

This Air Conditioner is a new type that has adopted a new refrigerant HFC (R410A) instead of the conventional refrigerant R22 in order to prevent destruction of the ozone layer.

This equipment complies with IEC 61000-3-12 provided that the short-circuit power  $S_{sc}$  is greater than or equal to  $S_{sc} (*1)$  at the interface point between the user's supply and the public system. It is the responsibility of the installer or user of the equipment to ensure, by consultation with the distribution network operator if necessary, that the equipment is connected only to a supply with a short-circuit power  $S_{sc}$  greater than or equal to  $S_{sc} (*1)$ .

$S_{sc} (*1)$

Model	$S_{sc}$ (MVA)
RAV-SM2244AT8(Z)(ZG)-E	1.41
RAV-SM2804AT8(Z)(ZG)-E	1.72







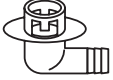

## Contents

---

<b>1</b>	<b>ACCESSORY PARTS</b>	<b>2</b>
<b>2</b>	<b>SAFETY PRECAUTIONS</b>	<b>3</b>
<b>3</b>	<b>INSTALLATION OF NEW REFRIGERANT AIR CONDITIONER</b>	<b>4</b>
<b>4</b>	<b>INSTALLATION CONDITIONS</b>	<b>6</b>
<b>5</b>	<b>REFRIGERANT PIPING</b>	<b>10</b>
<b>6</b>	<b>AIR PURGING</b>	<b>14</b>
<b>7</b>	<b>ELECTRICAL WORK</b>	<b>17</b>
<b>8</b>	<b>EARTHING</b>	<b>19</b>
<b>9</b>	<b>FINISHING</b>	<b>20</b>
<b>10</b>	<b>TEST RUN</b>	<b>20</b>
<b>11</b>	<b>ANNUAL MAINTENANCE</b>	<b>20</b>
<b>12</b>	<b>AIR CONDITIONER OPERATING CONDITIONS</b>	<b>20</b>
<b>13</b>	<b>FUNCTIONS TO BE IMPLEMENTED LOCALLY</b>	<b>21</b>
<b>14</b>	<b>TROUBLESHOOTING</b>	<b>22</b>
<b>15</b>	<b>APPENDIX</b>	<b>24</b>

# 1 ACCESSORY PARTS

## ■ Accessory Parts

Part name	Q'ty	Shape	Usage
Installation manual	1		(Hand this directly to the customer.)
Drain nipple	1		
Waterproof rubber cap	1		
Protective bush	1		For protecting wires (pipe cover)
Guard material for passage part	1		For protecting passage part (pipe cover)
Clamp filter	1		For conforming to EMC standards (Used for power wire)
Ø19.1 mm pipe	1		For the pipe inside the outdoor unit
Joint (Ø19.1 – Ø25.4 mm)	1		For connecting the pipe
Joint (Ø25.4 – Ø28.6 mm)	1		For connecting the pipe
Elbow	1		For connecting the pipe

## INFORMATION

- The main pipe on the gas side of this outdoor unit has a diameter of Ø28.6 mm, but a Ø19.1 mm flare connection is used where the valve is connected. Be sure to use the Ø19.1 mm pipe and joint provided as accessories for the pipe connection.
- Before installing the unit, check that the unit has the correct model name to prevent the wrong unit from being installed in the wrong place.
- Before proceeding to weld the refrigerant pipe, be sure to pass nitrogen through the pipe.
- Before installing the indoor units, read the instructions in the installation manual provided with the indoor units.
- Before installing a branch pipe, read the instructions in the installation manual provided with the branch pipe kit.
- In the case of a simultaneous double twin system, use indoor unit with the same capacity for all four indoor units.

	Branch pipe kit	Combination indoor unit
RAV-SM2244	RBC-DTWP101E	SM56 × 4 units
RAV-SM2804	RBC-DTWP101E	SM80 × 4 units

- P.C. board settings are required for some of the indoor units if they are to be used in a twin, triple or double twin system. Refer to the instructions in the installation manual of the branch pipe kit, and ensure that the settings are selected correctly.
- Combination with the indoor units  
Combination with the indoor units is possible only when units with the same type are combined. Combinations of units with different types cannot be used.

## 2 SAFETY PRECAUTIONS

- Ensure that all Local, National and International regulations are satisfied.
- Read these "SAFETY PRECAUTIONS" carefully before installation.
- The precautions described below include important items regarding safety. Observe them without fail.
- After the installation work, perform a trial operation to check for any problem. Follow the Owner's Manual to explain to the customer how to use and maintain the unit.
- Ask the customer to keep the Installation Manual together with the Owner's Manual.

### WARNING

- **Ask an authorized dealer or qualified installation professional to install/maintain the air conditioner. Perform installation work properly according to the Installation Manual.**  
Inappropriate installation may result in water leakage, electric shock or fire.
- **Be sure to connect earth wire (grounding work).**  
Incomplete grounding cause an electric shock.  
Do not connect ground wires to gas pipes, water pipes, lightning rods or ground wires for telephone wires.
- **Turn off the main power supply switch or breaker before attempting any electrical work and maintenance.**  
Make sure all power switches are off. Failure to do so may cause electric shock.  
Use an exclusive power circuit for the air conditioner. Use the rated voltage.
- **Connect the connecting wire correctly.**  
If the connecting wire is incorrect, electric parts may be damaged.
- **When moving the air conditioner for installation to another place, be very careful not to allow the specified refrigerant (R410A) to become mixed with any other gaseous body into the refrigeration cycle.**  
If air or any other gas mixes with the refrigerant, the gas pressure in the refrigeration cycle will become abnormally high and it may result in the pipe bursting or personal injuries.
- **Do not modify this unit by removing any of the safety guards or by by-passing any of the safety interlock switches.**
- **Do not touch the intake or aluminum fins of the outdoor unit.**  
Doing so may result in injury.
- **Tighten the flare nut with a torque wrench in the specified manner.**  
Excessive tightening of the flare nut may cause a crack in the flare nut after a long period, which may result in refrigerant leakage.
- **Install the air conditioner securely in a location where the base can sustain the weight of the unit adequately.**
- **Perform the specified installation work to guard against an earthquake.**  
If the air conditioner is not installed appropriately, accidents may occur due to the unit falling.
- **If refrigerant gas has leaked during the installation work, ventilate the room immediately.**  
If the leaked refrigerant gas comes in contact with fire, noxious gas may be generated.
- **After the installation work, confirm that refrigerant gas does not leak.**  
If refrigerant gas leaks into the room and flows near a fire source, such as a cooking range, noxious gas may be generated.
- **Electrical work must be performed by a qualified electrician in accordance with the Installation Manual. Make sure the air conditioner uses an exclusive power supply.**  
An insufficient power supply capacity or inappropriate installation may cause fire.
- **Use only the specified wiring during the unit installation. Ensure that all terminals are securely fixed, so preventing any external forces having a negative effect on the terminals.**
- **When the air conditioner cannot cool or heat a room well, contact the dealer from whom you purchased the air conditioner as refrigerant leakage is considered as the cause.**  
**In the case of repair that requires refill of refrigerant, ask service personnel about details of the repair.**  
The refrigerant used in the air conditioner is harmless.  
Generally, the refrigerant does not leak. However, if the refrigerant leaks in a room and a heater or stove burner in the room catches fire, it may generate toxic gas.  
When you ask service personnel for repairing refrigerant leakage, confirm that the leakage portion has been completely repaired.
- **Conform to the regulations of the local electric company when wiring the power supply.**  
Inappropriate grounding may cause electric shock.
- **Do not install the air conditioner in a location that may be subjected to a risk of exposure to a combustible gas.**  
If a combustible gas leaks and becomes concentrated around the unit, a fire may occur.

- **Install the refrigerant pipe securely during the installation work before operating the air conditioner.**  
If the compressor is operated with the valve open and without the refrigerant pipe, the compressor sucks air and the refrigeration cycle is overpressurized, which may cause a burst or injury.
  - **When carrying out the pump-down work, shut down the compressor before disconnecting the refrigerant pipe.**  
Disconnecting the refrigerant pipe with the service valve left open and with the compressor still operating will cause air, etc. to be sucked in, raising the pressure inside the refrigeration cycle to an abnormally high level, and possibly resulting in rupturing, injury, etc.
- 

### CAUTION

---

- **Do not climb onto or place objects on top of the outdoor unit.**  
You may fall or the objects may fall off of the outdoor unit and result in injury.
- **Wear heavy gloves during the installation work to avoid injury.**

#### **To Disconnect the Appliance from the Main Power Supply**

- This appliance must be connected to the main power supply by means of a switch with a contact separation of at least 3 mm.
  - A 25 A installation fuse (all fuse types can be used) must be used for the power supply line of this conditioner.
- 

## 3 INSTALLATION OF NEW REFRIGERANT AIR CONDITIONER

### CAUTION

---

#### **New Refrigerant Air Conditioner Installation**

- **THIS AIR CONDITIONER ADOPTS THE NEW HFC REFRIGERANT (R410A) WHICH DOES NOT DESTROY OZONE LAYER.**

R410A refrigerant is apt to be affected by impurities such as water, oxidizing membrane, and oils because the working pressure of R410A refrigerant is approx. 1.6 times as that of refrigerant R22. Accompanied with the adoption of the new refrigerant, the refrigerant oil has also been changed. Therefore, during installation work, be sure that water, dust, former refrigerant, or refrigerant oil does not enter the new type refrigerant R410A air conditioner cycle.

To prevent mixing of refrigerant or refrigerant oil, the sizes of connecting sections of charging port on main unit and installation tools are different from those of the conventional refrigerant units. Accordingly, special tools are required for the new refrigerant (R410A) units. For connecting pipes, use new and clean piping materials with high pressure fittings made for R410A only, so that water and/or dust does not enter.

---

## ■ Required Tools/Equipment and Precautions for Use

Prepare the tools and equipment listed in the following table before starting the installation work. Newly prepared tools and equipment must be used exclusively.

### Legend

△ : Prepared newly (Use for R410A only. Do not use for refrigerant R22 or R407C etc.)

⊙ : Conventional tools/equipment are available

Tools/equipment	Use	How to use tools/equipment
Gauge manifold	Vacuuming/charging refrigerant and operation check	△ Prepared newly for R410A only
Charging hose		△ Prepared newly for R410A only
Charging cylinder	Can not be used	Unusable (Use the refrigerant charging measure instead.)
Gas leak detector	Gas leak check	△ Prepared newly
Vacuum pump	Vacuum drying	Unusable
Vacuum pump with backflow prevention function	Vacuum drying	⊙ R22 (Conventional tools)
Flare tool	Flare machining of pipes	⊙ Usable if dimensions are adjusted.
Bender	Bending pipes	⊙ R22 (Conventional tools)
Refrigerant recovery equipment	Refrigerant recovery	△ For R410A only
Torque wrench	Tightening flare nuts	△ Exclusive for Ø12.7 mm and Ø19.1 mm
Pipe cutter	Cutting pipes	⊙ R22 (Conventional tools)
Welding machine and nitrogen cylinder	Welding pipes	⊙ R22 (Conventional tools)
Refrigerant charging measure	Charging refrigerant	⊙ R22 (Conventional tools)

## ■ Refrigerant Piping

### New refrigerant (R410A)

#### When using the conventional piping

- When using the conventional piping with no indication of applicable refrigerant types, be sure to use it with a wall thickness of 0.8 mm for Ø6.4 mm, Ø9.5 mm, and Ø12.7 mm, with a wall thickness of 1.0 mm for Ø15.9 mm, with a wall thickness of 1.2 mm for Ø19.1 mm, and with a wall thickness of 1.0 mm for Ø28.6 mm (half hard). Do not use the conventional piping with a wall thickness less than these thicknesses due to insufficient pressure capacity.

#### When using general copper pipes

- Use general copper pipes with a wall thickness of 0.8 mm for Ø6.4 mm, Ø9.5 mm, and Ø12.7 mm, with a wall thickness of 1.0 mm for Ø15.9 mm, with a wall thickness of 1.2 mm for Ø19.1 mm, and with a wall thickness of 1.0 mm for Ø28.6 mm (half hard).  
Do not use any copper pipes with a wall thickness less than these thicknesses.

#### Flare nuts and flare machining

- The flare nuts and flare machining are different from those for the conventional refrigerant.  
Use the flare nuts supplied with the air conditioner or those for R410A.
- Before performing flare machining, carefully read "REFRIGERANT PIPING".

# 4 INSTALLATION CONDITIONS

## ■ Before installation

Be sure to prepare to the following items before installation.

### Length of refrigerant pipe

Length of refrigerant pipe connected to indoor/ outdoor unit	Item
7.5 to 30 m	Addition of refrigerant is unnecessary at the local site.
*31 to 70 m	<Addition of refrigerant> Add 40 g of refrigerant for every 1 m of piping that exceeds 30 m.

- \* If the total length of the refrigerant pipe exceeds 30 m, add refrigerant in the amount given in the “Adding additional refrigerant”.
- \* Do not connect a refrigerant pipe that is shorter than **7.5 m**.  
This may cause a malfunction of the compressor or other devices.

### Airtight test

1. Before starting an airtight test, further tighten the spindle valves on the gas and liquid sides.
2. Pressurize the pipe with nitrogen gas charged from the service port to the design pressure (4.15 MPa) to conduct an airtight test.
3. After the airtight test is completed, evacuate the nitrogen gas.

### Air purge

- To purge air, use a vacuum pump.
- Do not use refrigerant charged in the outdoor unit to purge air. (The air purge refrigerant is not contained in the outdoor unit.)

### Electrical wiring

- Be sure to fix the power wires and indoor/outdoor connecting wires with clamps so that they do not come into contact with the cabinet, etc.

## Earthing

### **WARNING**

#### **Make sure that proper earthing is provided.**

Improper earthing may cause an electric shock. For details on how to check earthing, contact the dealer who installed the air conditioner or a professional installation company.

- Proper earthing can prevent charging of electricity on the outdoor unit surface due to the presence of a high frequency in the frequency converter (inverter) of the outdoor unit, as well as prevent electric shock. If the outdoor unit is not properly earthed, you may be exposed to an electric shock.
- **Be sure to connect the earth wire (grounding work).** Incomplete grounding can cause an electric shock. Do not connect ground wires to gas pipes, water pipes, lightning rods or ground wires for telephone wires.

### Test Run

Turn on the leakage breaker at least 12 hours before starting a test run to protect the compressor during startup.

### **CAUTION**

Incorrect installation work may result in a malfunction or complaints from customers.

## ■ Installation Location

### WARNING

**Install the outdoor unit properly in a location that is durable enough to support the weight of the outdoor unit.**

Insufficient durability may cause the outdoor unit to fall, which may result in injury.  
This outdoor unit has a weight of about 135 kg. Pay special attention when installing the unit onto a wall surface.

### CAUTION

**Do not install the outdoor unit in a location that is subject to combustible gas leaks.**

Accumulation of combustible gas around the outdoor unit may cause a fire.

**Install the outdoor unit in a location that meets the following conditions after the customer's consent is obtained.**

- A well-ventilated location free from obstacles near the air inlets and air outlet
- A location that is not exposed to rain or direct sunlight
- A location that does not increase the operating noise or vibration of the outdoor unit
- A location that does not produce any drainage problems from discharged water

**Do not install the outdoor unit in the following locations.**

- A location with a saline atmosphere (coastal area) or one that is full of sulfide gas (hot-spring area) (Special maintenance is required.)
- A location subject to oil, vapor, oily smoke, or corrosive gases
- A location in which organic solvent is used
- A location where high-frequency equipment (including inverter equipment, private power generator, medical equipment, and communication equipment) is used (Installation in such a location may cause malfunction of the air conditioner, abnormal control or problems due to noise from such equipment.)
- A location in which the discharged air of the outdoor unit blows against the window of a neighboring house
- A location where the operating noise of the outdoor unit is transmitted
- When the outdoor unit is installed in an elevated position, be sure to secure its feet.
- A location in which drain water poses any problems.

### CAUTION

1. Install the outdoor unit in a location where the discharge air is not blocked.
2. When an outdoor unit is installed in a location that is always exposed to strong winds like a coast or on the high stories of a building, secure normal fan operation by using a duct or wind shield.
3. When installing the outdoor unit in a location that is constantly exposed to strong winds such as on the upper stairs or rooftop of a building, apply the windproofing measures referred to in the following examples.
  - 1) Install the unit so that its discharge port faces the wall of the building.  
Keep a distance 500 mm or more between the unit and wall surface.

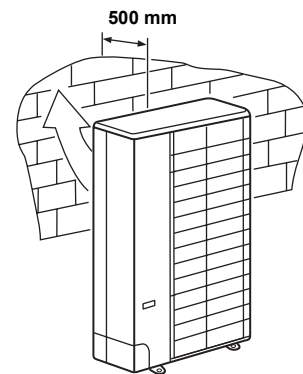

- 2) Consider the wind direction during the operational season of the air conditioner, and install the unit so that the discharge port is set at a right angle relative to the wind direction.

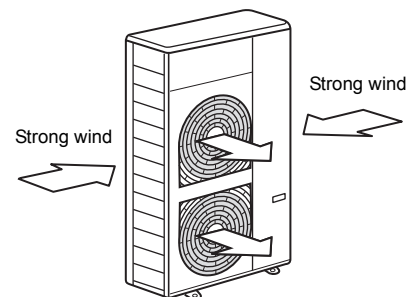

- When using an air conditioner under low outside temperature conditions (Outside temp: -5 °C or lower) in COOL mode, prepare a duct or wind shield so that it is not affected by the wind.

#### <Example>

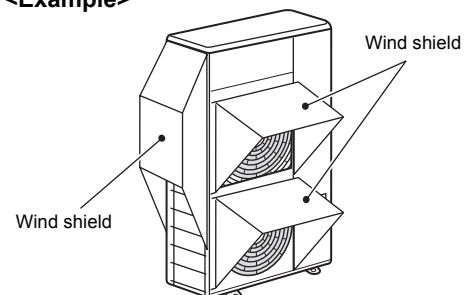

**■ Necessary Space for Installation  
(Unit: mm)**

**Obstacle at rear side**

**Upper side is free**

1. Single unit installation

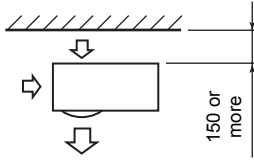

2. Obstacles on both right and left sides

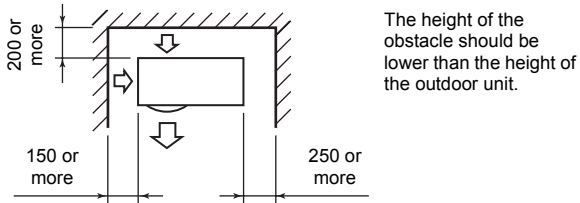

3. Serial installation of two or more units

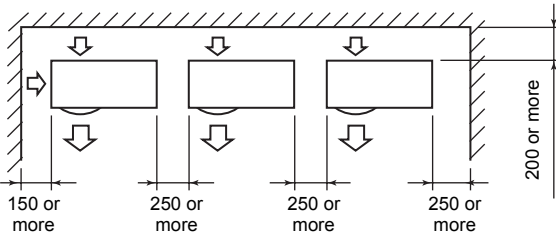

The height of the obstacle should be lower than the height of the outdoor unit.

**Obstacle also above unit**

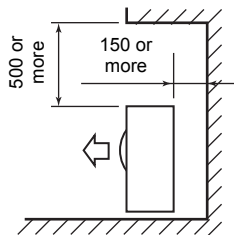

**Obstacle in front**

**Above unit is free**

1. Single unit installation

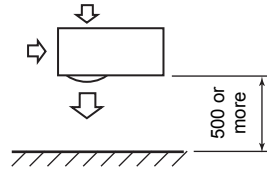

2. Serial installation of two or more units

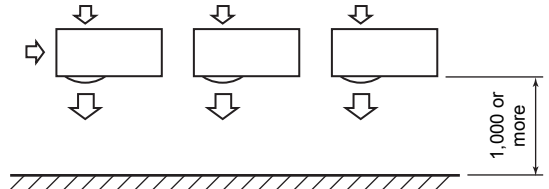

**Obstacle also at the above unit**

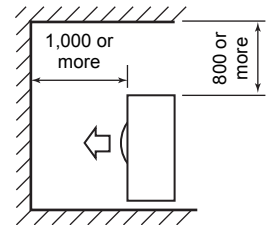

**Obstacles in both front and rear of unit**

Open above and to the right and left of the unit.

The height of an obstacle in both the front and rear of the unit, should be lower than the height of the outdoor unit.

**Standard installation**

1. Single unit installation

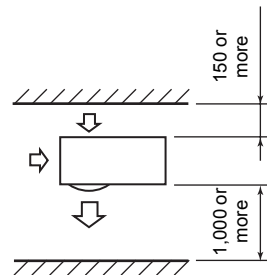

2. Serial installation of two or more units

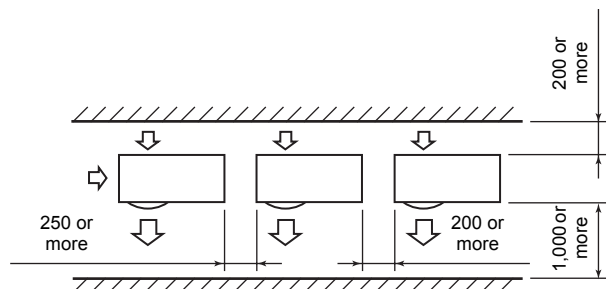

**Serial installation in front and rear**

Open above and to the right and left of the unit.  
The height of an obstacle in both the front and rear of the unit should be lower than the height of the outdoor unit.

**Standard installation**

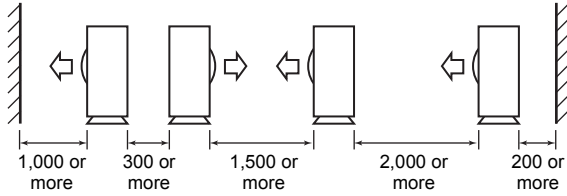

**Installation of Outdoor Unit**

- Before installation, check the strength and horizontalness of the base so that abnormal sounds do not emanate.
- According to the following base diagram, fix the base firmly with the anchor bolts.  
(Anchor bolt, nut: M10 x 4 pairs)

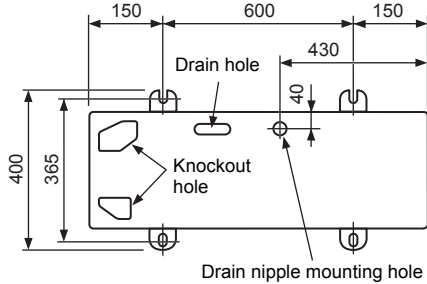

- As shown in the figure below, install the foundation and vibration-proof rubber pads to directly support the bottom surface of the fixing leg that is in contact with and underneath the bottom plate of the outdoor unit.
- \* When installing the foundation for an outdoor unit with downward piping, consider the piping work.

**GOOD**

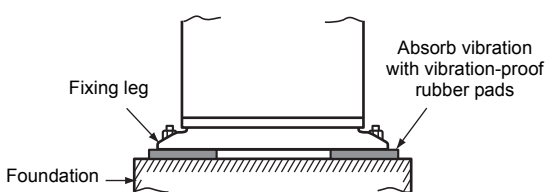

**GOOD**

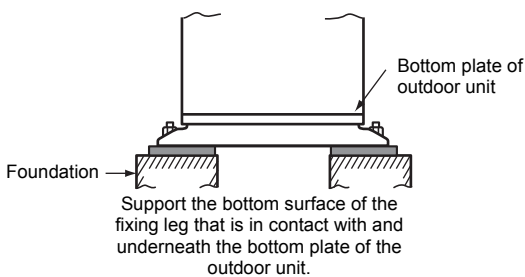

**NO GOOD**

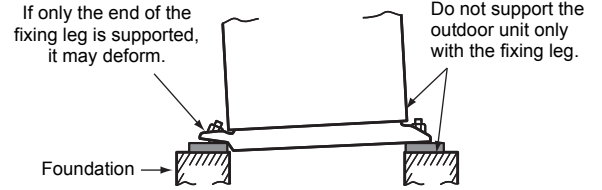

Set the out margin of the anchor bolt to 15 mm or less.

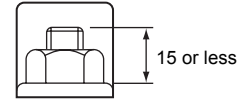

- When water is to be drained through the drain hose, attach the following drain nipple and waterproof rubber cap, and use the drain hose (Inner diam: 16 mm) sold on the market. Also seal the knockout hole and screws securely with silicone material, etc., to prevent water from leaking.  
Some conditions may cause dewing or dripping of water.
- When collectively draining discharged water completely, use a drain pan.

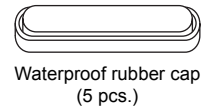
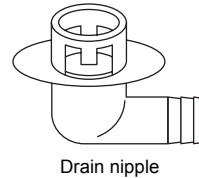

- Please pay attention to the drain in region with snowfall and cold temperature, as it may be frozen and cause drainage problems. Punch the knockout holes on the base plate to improve drainability. Use a screwdriver and take off the knockout part outward.

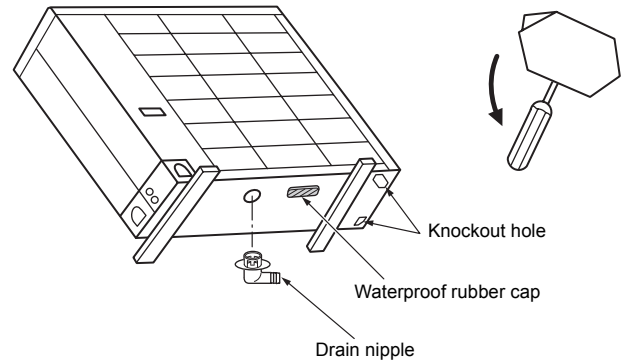

**For Reference**

If a heating operation is to be continuously performed for a long time under the condition that the outdoor temperature is 0 °C or lower, draining defrosted water may be difficult due to the bottom plate freezing, resulting in trouble with the cabinet or fan.

It is recommended to procure an anti-freeze heater locally in order to safely install the air conditioner.  
For details, contact the dealer.

# 5 REFRIGERANT PIPING

## ■ Knockout of Pipe Cover

### Knockout procedure

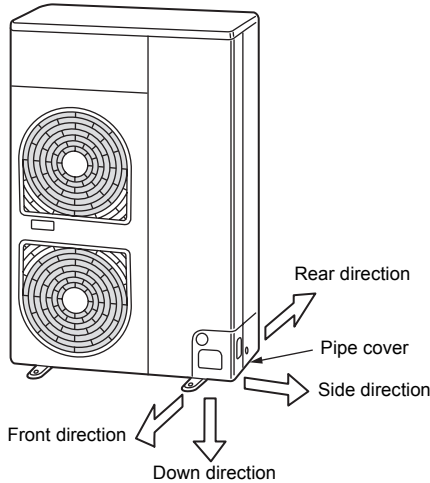

- The indoor/outdoor connecting pipes can be connected in 4 directions.  
Take off the knockout part of the pipe cover through which pipes or wires will pass through the base plate.
- Detach the pipe cover and tap on the knockout section a few times with the shank of a screwdriver. A knockout hole can easily be punched.
- As shown in the figure below, it is easier to punch out the knockout hole when the pipe cover is left in place rather than when the cover is removed from the unit.  
In knocking out the hole, the knockout section can easily be removed by hand once the bottom of the three locations where the section is joined along the guide lines is broken using a screwdriver.
- After punching out the knockout hole, remove burrs from the hole, and install the protective bush and guard material around the passage hole provided as accessories in order to protect the wires and pipes. Also be sure to attach the pipe covers after connecting the pipes. The pipe covers can be easily attached by cutting off the slits at the lower part of the covers.

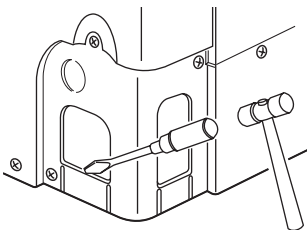

- \* Be sure to wear heavy work gloves while working.

## ■ Optional Installation Parts (Locally procured)

	Parts name	Q'ty
A	Refrigerant piping Liquid side: Ø12.7 mm Gas side: Ø19.1 mm (Approx. 800 mm) Ø28.6 mm	One each
B	Pipe insulating material (polyethylene foam, 10 mm thick)	1
C	Putty, PVC tape	One each

### REQUIREMENT

Follow the instructions in the installation manual provided with the branch pipe kit and the instructions in the installation manual of the indoor unit to connect the refrigerant pipe between the branch pipe and indoor unit.

## ■ Refrigerant Piping Connection

### CAUTION

#### TAKE NOTE OF THESE 4 IMPORTANT POINTS BELOW FOR PIPING WORK

1. Keep dust and moisture away from inside the connecting pipes.
2. Tightly connect the connection between pipes and the unit.
3. Evacuate the air in the connecting pipes using a VACUUM PUMP.
4. Check for gas leaks at connection points.

### Piping connection

Liquid side	
Outer diameter	Thickness
Ø12.7 mm	0.8 mm

Gas side	
Outer diameter	Thickness
Ø19.1 mm	1.2 mm
Ø28.6 mm	1.0 mm (half hard)

### REQUIREMENT

On the gas side, be sure to use the Ø19.1 mm pipe provided with the outdoor unit.

**Flaring**

1. Cut the pipe with a pipe cutter.  
Be sure to remove burrs that may cause a gas leak.
2. Insert a flare nut into the pipe, and then flare the pipe.  
Use the flare nuts supplied with the air conditioner or those for R410A.  
Insert a flare nut into the pipe, and flare the pipe.  
As the flaring sizes of R410A differ from those of refrigerant R22, the flare tools newly manufactured for R410A are recommended.  
However, the conventional tools can be used by adjusting the projection margin of the copper pipe.

**Projection margin in flaring: B (Unit: mm)**

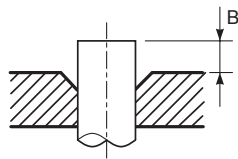

Rigid (Clutch type)

Outer diam. of copper pipe	R410A tool used	Conventional tool used
	R410A	
9.5	0 to 0.5	1.0 to 1.5
12.7		
15.9		
19.1		

**Flaring diameter size: A (Unit: mm)**

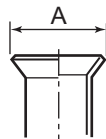

Outer diam. of copper pipe	A <sup>+0</sup> <sub>-0.4</sub>
9.5	13.2
12.7	16.6
15.9	19.7
19.1	24.0

\* In case of flaring for R410A with the conventional flare tool, pull the tool out approx. 0.5 mm more than that for R22 to adjust it to the specified flare size.  
The copper pipe gauge is useful for adjusting the projection margin size.

**■ Connecting the Gas Side Pipe**

**REQUIREMENT**

- Be sure to use the Ø19.1 mm pipe and joint provided as accessories of the outdoor unit to connect the gas side Ø19.1 mm pipe and Ø28.6 mm pipe.
- When leading out the pipes toward the front, to one of the sides or toward the rear, use the Ø19.1 mm pipe and elbow provided as accessories of the outdoor unit, and adjust the bending direction. Cut the Ø19.1 mm pipe to the required length before using it.

1. Align the provided Ø19.1 mm pipe with the pipe lead-out direction, and shape it so that its end comes out from the outdoor unit.
2. On the outside of the outdoor unit, use the provided joints, and braze the Ø19.1 mm pipe and Ø28.6 mm pipe.

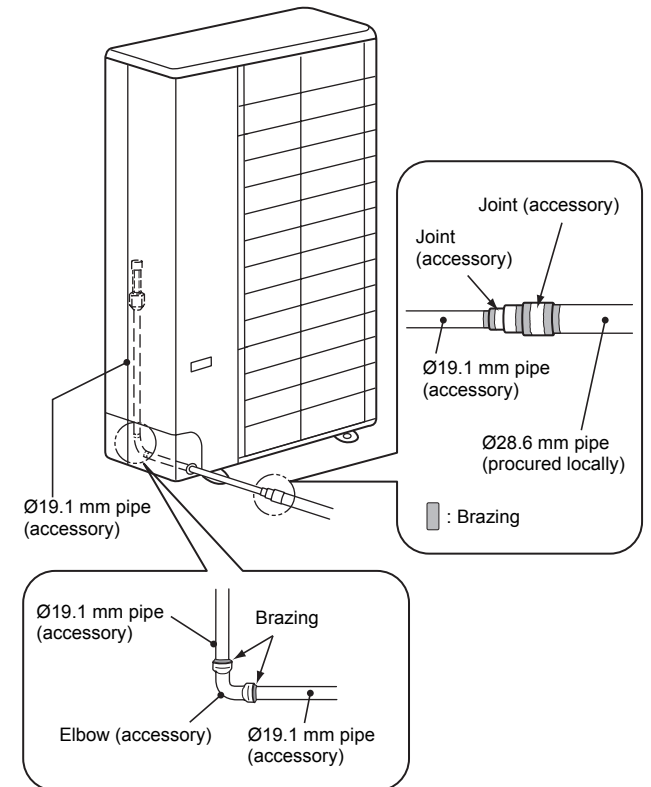

**REQUIREMENT**

- Before proceeding to weld the refrigerant pipe, be sure to pass nitrogen through the pipe to prevent oxidation inside it. If nitrogen is not passed through the pipe, the refrigerating cycle may become clogged by oxidized scales.
- The Ø28.6 mm pipe cannot be passed through the pipe cover and knockout hole in the base plate so be sure to connect the Ø19.1 mm pipe and Ø28.6 mm pipe outside the outdoor unit.

### ■ Tightening of Connecting Part

1. Align the centers of the connecting pipes and fully tighten the flare nut with your fingers. Then fix the nut with a wrench as shown in the figure and tighten it with a torque wrench.

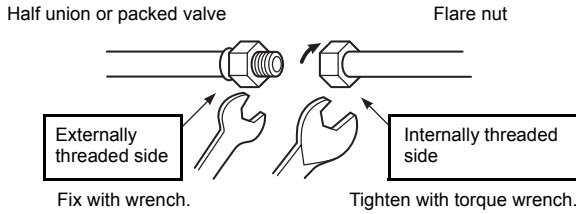

2. As shown in the figure, be sure to use two wrenches to loosen or tighten the flare nut of the valve on the gas side. If you use a single crescent, the flare nut cannot be tightened to the required tightening torque. On the other hand, use a single crescent to loosen or tighten the flare nut of the valve on the liquid side.

(Unit: N•m)

Outer dia. of copper pipe	Tightening torque
9.5 mm (diam.)	33 to 42 (3.3 to 4.2 kgf•m)
12.7 mm (diam.)	50 to 62 (5.0 to 6.2 kgf•m)
15.9 mm (diam.)	68 to 82 (6.8 to 8.2 kgf•m)
19.1 mm (diam.)	100 to 120 (10.0 to 12 kgf•m)

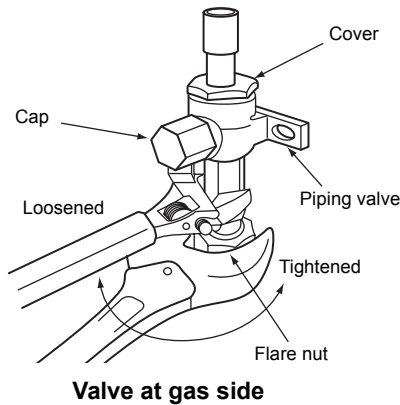

### ⚠ CAUTION

1. Do not put the crescent wrench on the cap or cover. The valve may break.
2. If applying excessive torque, the nut may break according to some installation conditions.

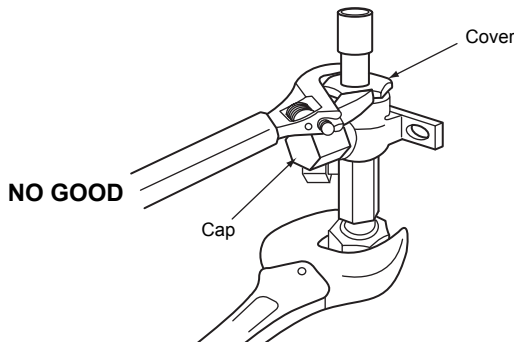

- After the installation work, be sure to check for gas leaks of the pipe connections with nitrogen.
- Pressure of R410A is higher than that of R22 (Approx. 1.6 times).

Therefore, using a torque wrench, tighten the flare pipe connecting sections that connect the indoor/outdoor units at the specified tightening torque.

Incomplete connections may cause not only a gas leak, but also trouble with the refrigeration cycle.

**Do not apply refrigerant oil to the flared surface.**

### ■ Branch Pipe

Carry out the refrigerant piping work using the branch pipe kit which is purchased separately.

#### Branch pipe installation

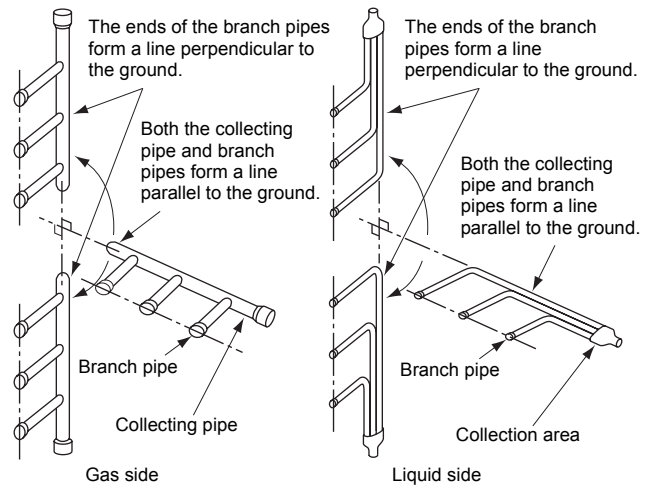

**NO GOOD**

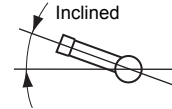

Make sure that the pipes are installed level after branching.

#### Length of straight sections on main pipe side of branch pipe

Provide a straight section with a length of at least 500 mm on the main pipe side of the branch pipe. (Same for both liquid side and gas side)

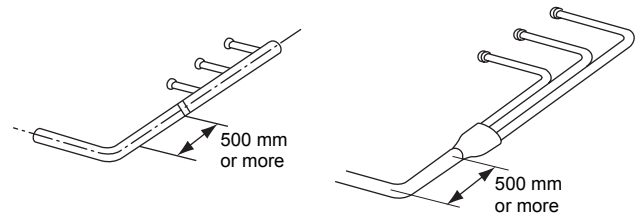

## ■ Refrigerant Pipe Length

### Simultaneous twin, triple

Outdoor unit	Allowable pipe length (m)			Height difference (m)		
	Total length • $l_1 + l_2$ • $l_1 + l_3$ • $l_1 + l_4$ Maximum	Branch piping • $l_2$ • $l_3$ • $l_4$ Maximum	Branch piping • $l_3 - l_2$ • $l_4 - l_2$ • $l_4 - l_3$ Maximum	Indoor-outdoor H		Indoor-indoor ( $\Delta h$ )
				Indoor unit: Upper	Outdoor unit: Upper	
SM2244	70	20	10	30	30	0.5
SM2804	70	20	10	30	30	0.5

Outdoor unit	Pipe diameter (mm)				Number of bent portions
	Main pipe		Branch piping		
	Gas side	Liquid side	Gas side	Liquid side	
SM2244	Ø28.6	Ø12.7	Ø15.9	Ø9.5	10 or less
SM2804	Ø28.6	Ø12.7	Ø15.9	Ø9.5	10 or less

Figure of Simultaneous twin

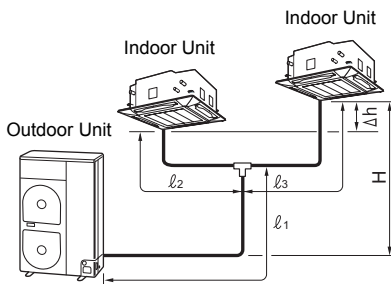
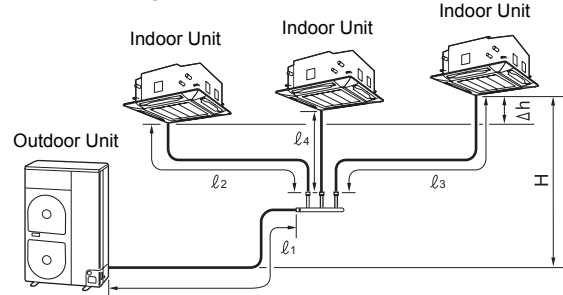

Figure of Simultaneous triple



### Simultaneous double twin

Outdoor unit	Allowable pipe length (m)				Height difference (m)		
	Total length • $l_1 + l_2 + l_4$ • $l_1 + l_2 + l_5$ • $l_1 + l_3 + l_6$ • $l_1 + l_3 + l_7$ Maximum	Branch piping • $l_4$ • $l_5$ • $l_6$ • $l_7$ Maximum	Branch piping • $l_4 + l_2$ • $l_5 + l_2$ • $l_6 + l_3$ • $l_7 + l_3$ Maximum	Branch piping • $(l_4 + l_2) - (l_5 + l_2)$ • $(l_4 + l_2) - (l_6 + l_3)$ • $(l_4 + l_2) - (l_7 + l_3)$ • $(l_5 + l_2) - (l_6 + l_3)$ • $(l_5 + l_2) - (l_7 + l_3)$ • $(l_6 + l_3) - (l_7 + l_3)$ Maximum	Indoor-outdoor H		Indoor-indoor ( $\Delta h$ )
					Indoor unit: Upper	Outdoor unit: Upper	
SM2244	70	15	20	6	30	30	0.5
SM2804	70	15	20	6	30	30	0.5

Outdoor unit	Pipe diameter (mm)				Number of bent portions
	Main pipe		Branch piping		
	Gas side	Liquid side	Gas side	Liquid side	
SM2244	Ø28.6	Ø12.7	$l_2, l_3$ : Ø15.9 $l_4, l_5, l_6, l_7$ : Ø12.7	$l_2, l_3$ : Ø9.5 $l_4, l_5, l_6, l_7$ : Ø6.4	10 or less
SM2804	Ø28.6	Ø12.7	$l_2$ to $l_7$ : Ø15.9	$l_2$ to $l_7$ : Ø9.5	10 or less

Figure of Simultaneous double twin

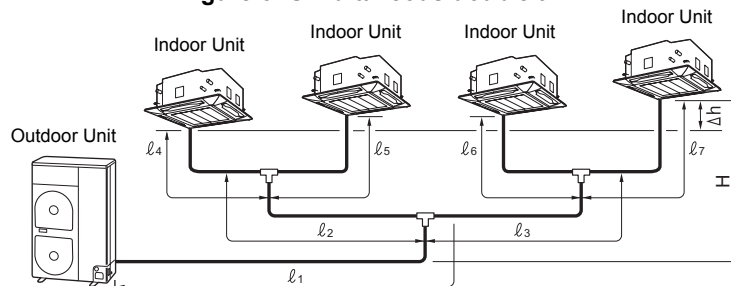

# 6 AIR PURGING

## ■ Airtight Test

Before starting an airtight test, further tighten the spindle valves on the gas side and liquid side.

Pressurize the pipe with nitrogen gas charged from the service port to the design pressure (4.15 MPa) to conduct the airtight test.

After the airtight test is completed, evacuate the nitrogen gas.

## ■ Air Purge

With respect to the preservation of the terrestrial environment, adopt "Vacuum pump" to purge air (Evacuate air in the connecting pipes) when installing the unit.

- Do not discharge the refrigerant gas to the atmosphere to preserve the terrestrial environment.
- Use a vacuum pump to discharge the air (nitrogen, etc.) that remains in the set. If air remains, the capacity may decrease.

For the vacuum pump, be sure to use one with a backflow preventer so that the oil in the pump does not backflow into the pipe of the air conditioner when the pump stops. (If oil in the vacuum pump is put in an air conditioner including R410A, it may cause trouble with the refrigeration cycle.)

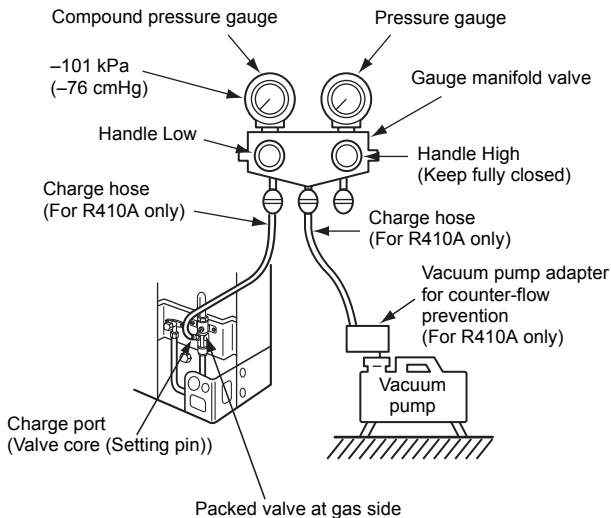

## Vacuum pump

- As shown in the figure, connect the charge hose after the manifold valve is closed completely.
- ↓
- Attach the connecting port of the charge hose with a projection to push the valve core (setting pin) to the charge port of the set.
- ↓
- Open Handle Low fully.
- ↓
- Turn ON the vacuum pump. (\*1)
- ↓
- Loosen the flare nut of the packed valve (Gas side) a little to check that the air passes through. (\*2)
- ↓
- Retighten the flare nut.
- ↓
- Execute vacuuming until the compound pressure gauge indicates  $-101 \text{ kPa}$  ( $-76 \text{ cmHg}$ ). (\*1)
- ↓
- Close Handle Low completely.
- ↓
- Turn OFF the vacuum pump.
- ↓
- Leave the vacuum pump as it is for 1 or 2 minutes, and check that the indicator of the compound pressure gauge does not return.
- ↓
- Open the valve stem or valve handle fully. (First, at liquid side, then gas side)
- ↓
- Disconnect the charge hose from the charge port.
- ↓
- Tighten the valve and caps of the charge port securely.

\*1 Use the vacuum pump, vacuum pump adapter, and gauge manifold correctly referring to the manuals supplied with each tool before using them. Check that the vacuum pump oil is filled up to the specified line of the oil gauge.

\*2 When air is not charged, check again whether the connecting port of the discharge hose, which has a projection to push the valve core, is firmly connected to the charge port.

## ■ How to Open the Valve

Open or close the valve.

### Liquid side

Open the valve with a 4 mm hexagon wrench.

### Gas side

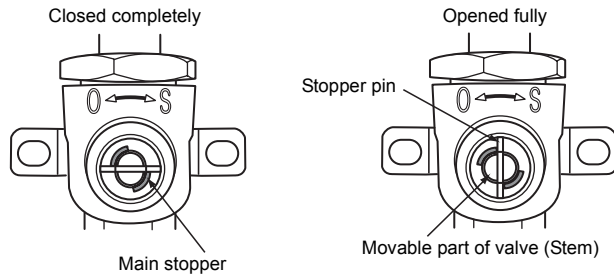
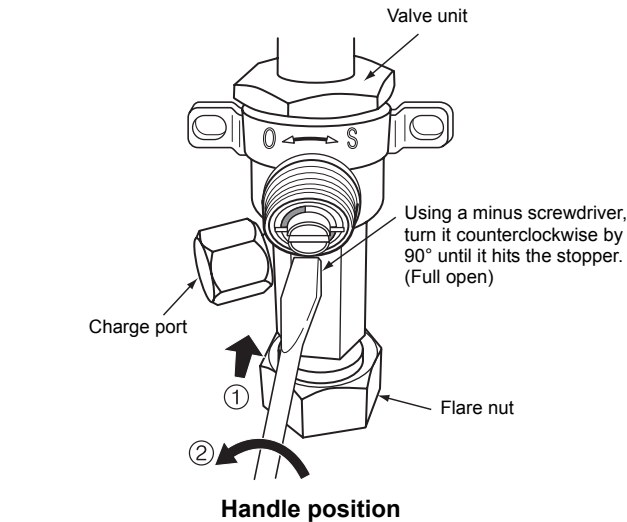

- While the valve is fully opened, after the screwdriver has reached the stopper, do not apply torque exceeding 5 N•m. Applying excessive torque may damage the valve.

### Valve handling precautions

- Open the valve stem until it strikes the stopper. It is unnecessary to apply further force.
- Securely tighten the cap with a torque wrench.

### Cap tightening torque

Valve size	Ø12.7 mm	50 to 62 N•m (5.0 to 6.2 kgf•m)
	Ø19.1 mm	20 to 25 N•m (2.0 to 2.5 kgf•m)
Charge port		14 to 18 N•m (1.4 to 1.8 kgf•m)

## ■ Insulating the Pipes

- The temperatures at both the liquid side and gas side will be low during cooling so in order to prevent condensation, be sure to insulate the pipes at both of these sides.
- Insulate the pipes separately for the liquid side and gas side.
- Insulate the branch pipes by following the instructions in the installation manual provided with the branch pipe kit.
- Use the insulating material provided as an accessory to insulate the Ø19.1 mm pipe at the gas side.
- Seal the area where the Ø19.1 mm pipe and Ø22.2 to Ø28.6 mm pipe are connected so that no gaps are left.

### REQUIREMENT

Be sure to use an insulating material which can withstand temperatures above 120°C for the gas side pipe since this pipe will become very hot during heating operations.

## ■ Replenishing Refrigerant

This model is a 30 m chargeless type that does not need to have its refrigerant replenished for refrigerant pipes up to 30 m. When a refrigerant pipe longer than 30 m is used, add the specified amount of refrigerant.

### Refrigerant replenishing procedure

1. After vacuuming the refrigerant pipe, close the valves and then charge the refrigerant while the air conditioner is not working.
2. When the refrigerant cannot be charged to the specified amount, charge the required amount of refrigerant from the charge port of the valve on the gas side during cooling.

### Requirement for replenishing refrigerant

Replenish liquid refrigerant.

When gaseous refrigerant is replenished, the refrigerant composition varies, which disables normal operation.

**Adding additional refrigerant**

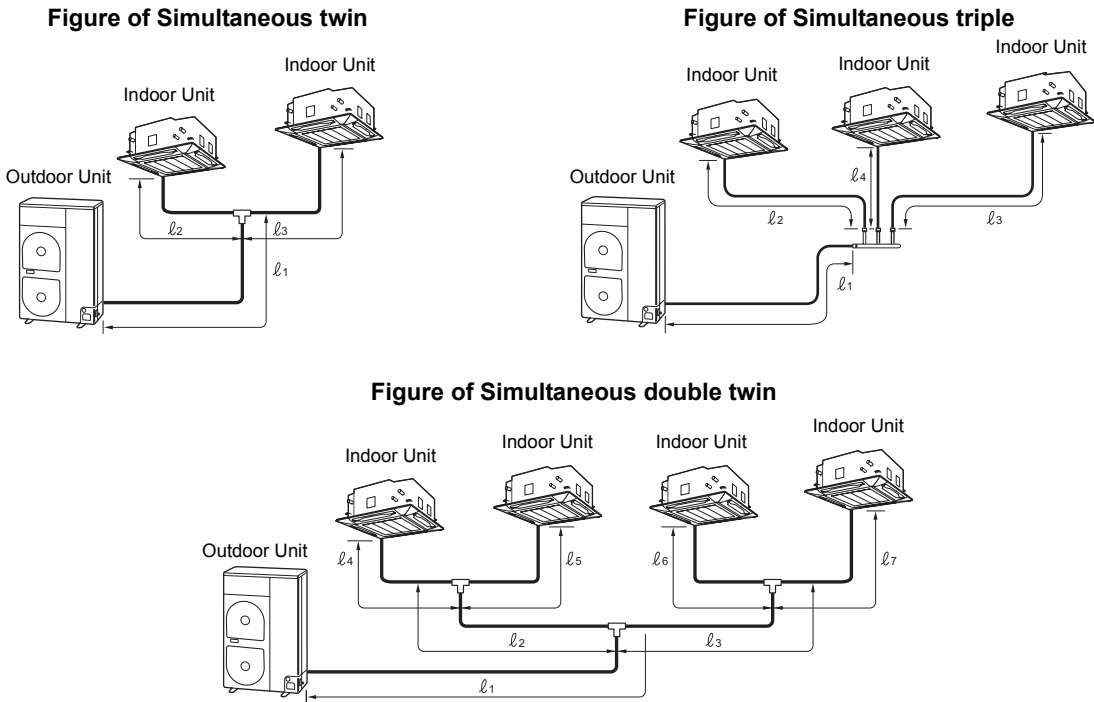

**Formula for calculating the amount of additional refrigerant**  
 (Formula will differ depending on the diameter of the liquid connecting side pipe.)

\*  $l_1$  to  $l_7$  are the lengths of the pipes shown in the figures above (unit: m).

**Simultaneous twin**

Diameter of connecting pipe (liquid side)			Amount of additional refrigerant per meter (g/m)		Amount of additional refrigerant (g) = Amount of refrigerant added for main pipe + amount of refrigerant added for branch piping
$l_1$	$l_2$	$l_3$	$\alpha$	$\beta$	
Ø12.7	Ø9.5	Ø9.5	80	40	$\alpha \times (l_1 - 28) + \beta \times (l_2 + l_3 - 4)$

**Simultaneous triple**

Diameter of connecting pipe (liquid side)				Amount of additional refrigerant per meter (g/m)		Amount of additional refrigerant (g) = Amount of refrigerant added for main pipe + amount of refrigerant added for branch piping
$l_1$	$l_2$	$l_3$	$l_4$	$\alpha$	$\beta$	
Ø12.7	Ø9.5	Ø9.5	Ø9.5	80	40	$\alpha \times (l_1 - 28) + \beta \times (l_2 + l_3 + l_4 - 6)$

**Simultaneous double twin**

Outdoor unit	Diameter of connecting pipe (liquid side)			Amount of additional refrigerant per meter (g/m)			Amount of additional refrigerant (g) = Amount of refrigerant added for main pipe + amount of refrigerant added for first branch piping + amount of refrigerant added for second branch piping
	$l_1$	$l_2, l_3$	$l_4$ to $l_7$	$\alpha$	$\beta$	$\gamma$	
<b>SM2244</b>	Ø12.7	Ø9.5	Ø6.4	80	40	20	$\alpha \times (l_1 - 28) + \beta \times (l_2 + l_3 - 4) + \gamma \times (l_4 + l_5 + l_6 + l_7)$
<b>SM2804</b>	Ø12.7	Ø9.5	Ø9.5	80	40	40	$\alpha \times (l_1 - 28) + \beta \times (l_2 + l_3 - 4) + \gamma \times (l_4 + l_5 + l_6 + l_7)$

# 7 ELECTRICAL WORK

## ⚠ WARNING

1. **Using the specified wires, ensure that the wires are connected, and fix wires securely so that the external tension to the wires does not affect the connecting part of the terminals.**  
Incomplete connection or fixation may cause a fire, etc.
2. **Be sure to connect the earth wire (grounding work). Incomplete grounding may lead to electric shock.**  
Do not connect ground wires to gas pipes, water pipes, lightning rods or ground wires for telephone wires.
3. **The appliance shall be installed in accordance with national wiring regulations.**  
Capacity shortages of the power circuit or an incomplete installation may cause an electric shock or fire.

## ⚠ CAUTION

- Wrong wiring may cause a burn-out of some electrical parts.
  - Be sure to use the cord clamps attached to the product.
  - Do not damage or scratch the conductive core or inner insulator of the power and inter-connecting wires when peeling them.
  - Use the power and inter-connecting wires with specified thicknesses, specified types and protective devices required.
- Remove the panel, and you can see electric parts on the front side.
  - A metal pipe can be installed through the hole for wiring. If the hole size does not fit the wiring pipe to be used, drill the hole again to an appropriate size.

Furthermore, be sure to secure these wires with the pipe valve fixing plate and cord clamps stored in the electric parts box.

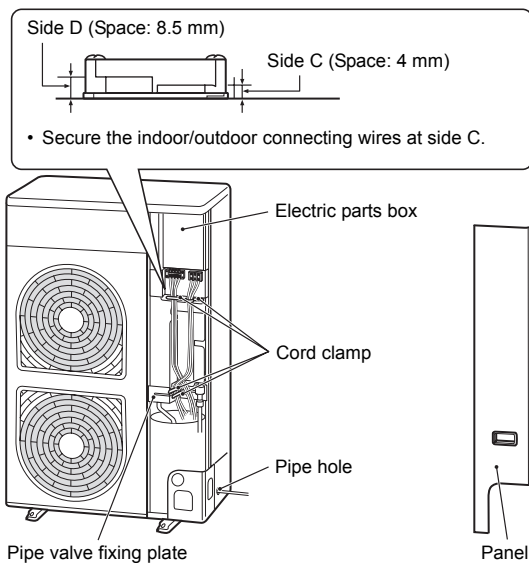

- When the outdoor air temperature drops, power is supplied to the compressor with the purpose of preheating the compressor in order to protect it. Therefore, leave the main power switch at the "on" setting during the periods when the air conditioner is being used.

## ■ Wiring between Indoor Unit and Outdoor Unit

1. Figure below shows the wiring connections between the standard indoor and outdoor units and between the indoor units and remote controller. The wires indicated by the broken lines or dot-and-dash lines are provided at the installation place.
2. Refer to the wiring diagrams of the models concerned for the internal wiring connections of the outdoor unit and indoor units.
3. There is no need to perform the P.C. board settings for the indoor units.

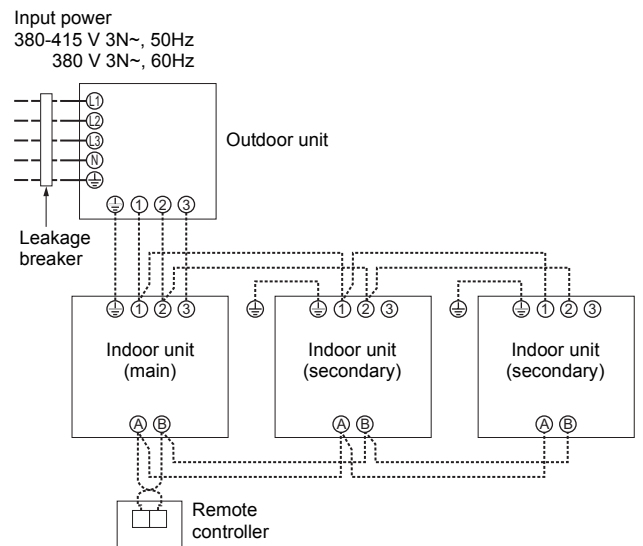

## ■ Power and Wiring Specifications

Model (RAV-SM Type)	224AT8	280AT8	224AT7	280AT7
Power supply	380-415 V 3N~ 50 Hz		380 V 3N~ 60 Hz	
Maximum running current	18.0 A	22.0 A	18.0 A	22.0 A
Installation fuse rating	25 A	25 A	25 A	25 A
Power wire*	5 × 2.5 mm <sup>2</sup> or more (H07 RN-F or 60245 IEC 66)			
Indoor/outdoor connecting wires*	4 × 1.5 mm <sup>2</sup> or more (H07 RN-F or 60245 IEC 66)			

\* Number of wire × wire size

**How to wire**

1. Connect the connecting wire to the terminal as identified with their respective numbers on the terminal block of the indoor and outdoor units.  
H07 RN-F or 60245 IEC 66 (1.5 mm<sup>2</sup> or more)
2. When connecting the connecting wire to the outdoor unit terminal, prevent water from coming into the outdoor unit.
3. Secure the power supply wire and indoor/outdoor connecting wires using the cord clamp of the outdoor unit.
4. For interconnecting wires, do not use a wire joined to another on the way.  
Use wires long enough to cover the entire length.
5. **Wiring connections differ in conformance to EMC standards, depending whether the system is twin, triple or double twin. Connect wires according to respective instructions.**

**CAUTION**

- An installation fuse must be used for the power supply line of this air conditioner.
- Incorrect/incomplete wiring may lead to an electrical fire or smoke.
- Prepare an exclusive power supply for the air conditioner.
- This product can be connected to the mains power.  
Fixed wire connections:  
A switch that disconnects all poles and has a contact separation of at least 3 mm must be incorporated in the fixed wiring.

**Wiring diagram**

\* For details on the remote controller wiring/installation, refer to the Installation Manual enclosed with the remote controller.

**Simultaneous twin system**

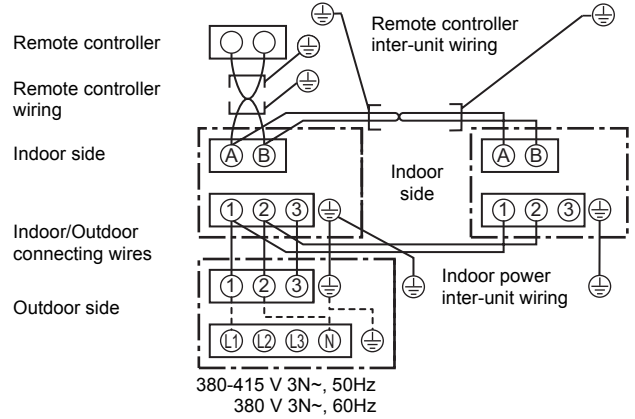

**Simultaneous triple and double twin system**

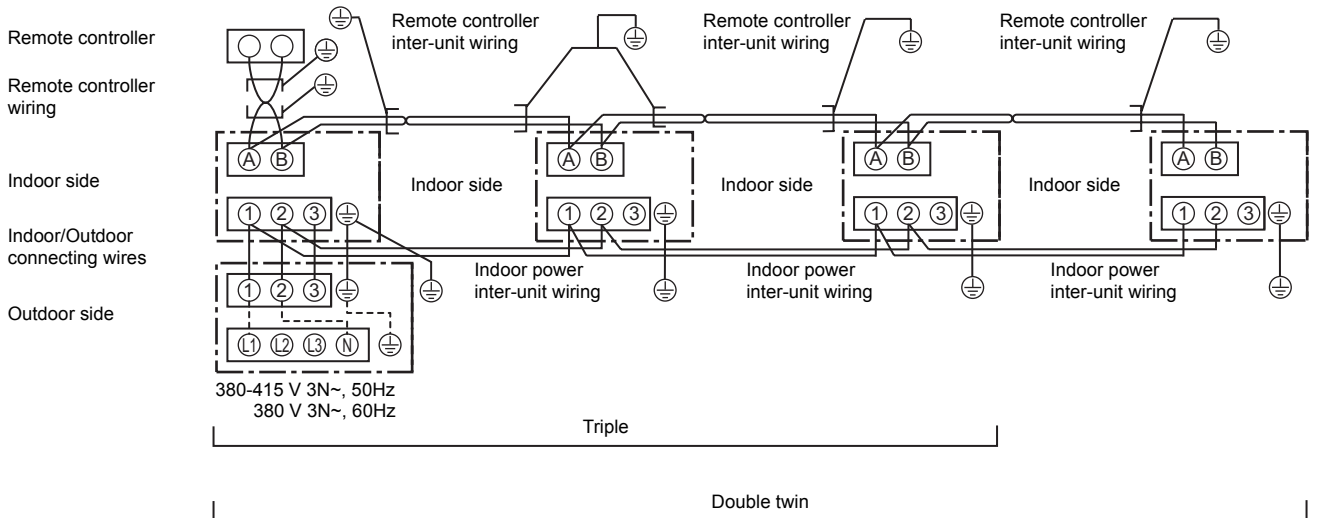

- \* Use 2-core shield wire (MVVS 0.5 to 2.0 mm<sup>2</sup> or more) for the remote controller wiring in the simultaneous twin, simultaneous triple and simultaneous double twin systems to prevent noise problems. Be sure to connect both ends of the shield wire to earth leads.
- \* Connect earth wires for each indoor unit in the simultaneous twin, simultaneous triple and simultaneous double twin systems.

**Stripping length power cord and connecting wire**

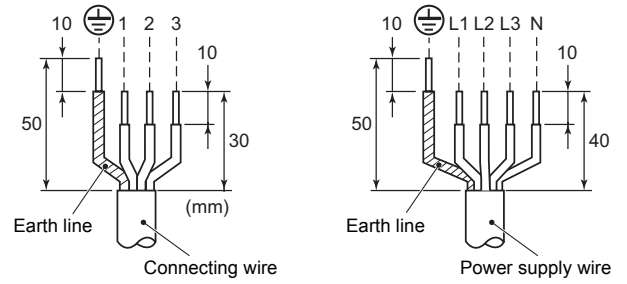
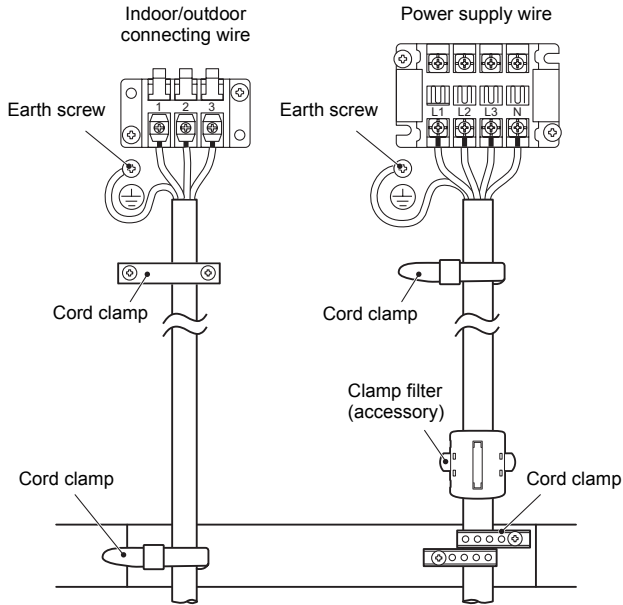

**⚠ WARNING**

Be sure to attach the provided clamp filter to the power supply wire in order to conform to EMC standards.

# 8 EARTHING

**⚠ WARNING**

- **Be sure to connect the earth wire. (grounding work)**  
Incomplete grounding may cause an electric shock.

Connect the earth line properly following applicable technical standards. Connecting the earth line is essential to preventing electric shock and to reducing noise and electrical charges on the outdoor unit surface due to the high-frequency wave generated by the frequency converter (inverter) in the outdoor unit. If you touch the charged outdoor unit without an earth line, you may experience an electric shock.

## 9 FINISHING

After the refrigerant pipe, inter-unit wires, and drain pipe have been connected, cover them with finishing tape and clamp them to the wall with off-the-shelf support brackets or their equivalent.

Keep the power wires and indoor/outdoor connecting wires off the valve on the gas side or pipes that have no heat insulator.

## 10 TEST RUN

- **Turn on the leakage breaker at least 12 hours before starting a test run to protect the compressor during startup.**  
To protect the compressor, power is supplied from the 380-415 VAC input to the unit to preheat the compressor.
- **Check the following before starting a test run:**
  - **That all pipes are connected securely without leaks.**
  - **That the valve is open.**  
If the compressor is operated with the valve closed, the outdoor unit will become overpressurized, which may damage the compressor or other components.  
If there is a leak at a connection, air can be sucked in and the internal pressure further increases, which may cause a burst or injury.
- Operate the air conditioner in the correct procedure as specified in the Owner's Manual.

## 11 ANNUAL MAINTENANCE

- For an air conditioning system that is operated on a regular basis, cleaning and maintenance of the indoor/outdoor units are strongly recommended.  
As a general rule, if an indoor unit is operated for about 8 hours daily, the indoor/outdoor units will need to be cleaned at least once every 3 months. This cleaning and maintenance should be carried out by a qualified service person.  
Failure to clean the indoor/outdoor units regularly will result in poor performance, icing, water leaking and even compressor failure.

## 12 AIR CONDITIONER OPERATING CONDITIONS

For proper performance, operate the air conditioner under the following temperature conditions:

Cooling operation	Dry valve temp.	-15°C to 46°C
Heating operation	Wet valve temp.	-20°C to 15°C

If air conditioner is used outside of the above conditions, safety protection may work.

# 13 FUNCTIONS TO BE IMPLEMENTED LOCALLY

## ■ Handling Existing Pipe

When using the existing pipe, carefully check for the following:

- Wall thickness (within the specified range)
- Scratches and dents
- Water, oil, dirt, or dust in the pipe
- Flare looseness and leakage from welds
- Deterioration of copper pipe and heat insulator
- Before recovering the refrigerant in the existing system, perform a cooling operation for at least 30 minutes.

### Cautions for using existing pipe

- Do not reuse a flare nut to prevent gas leaks. Replace it with the supplied flare nut and then process it to a flare.
- Blow nitrogen gas or use an appropriate means to keep the inside of the pipe clean. If discolored oil or much residue is discharged, wash the pipe.
- Check welds, if any, on the pipe for gas leaks.
- There may be a problem with the pressure resistance of the branching pipes of the existing piping. Replace them with branch pipes (sold separately).

When the pipe corresponds to any of the following, do not use it. Install a new pipe instead.

- The pipe has been opened (disconnected from indoor unit or outdoor unit) for a long period.
- The pipe has been connected to an outdoor unit that does not use refrigerant R22, R410A or R407C.
- The existing pipe must have a wall thickness equal to or larger than the following thicknesses.

Reference outside diameter (mm)	Wall thickness (mm)	Material
6.4	0.8	—
9.5	0.8	—
12.7	0.8	—
15.9	1.0	—
19.1	1.2	—
22.2	1.0	Half hard
28.6	1.0	Half hard

- Do not use any pipe with a wall thickness less than these thicknesses due to insufficient pressure capacity.

- When using a  $\varnothing 19.1$  mm gas pipe for the existing piping, set bit 3 of SW802 (switch for existing pipe) on the P.C. board of the outdoor unit to ON. In this case, the heating performance may be reduced depending on the outside air temperature and room temperature.

SW802	
When shipped from factory	When using existing pipe

## ■ Recovering Refrigerant

Use the refrigerant recovery equipment to recover the refrigerant.

# 14 TROUBLESHOOTING

You can perform fault diagnosis of the outdoor unit with the LEDs on the P.C. board of the outdoor unit in addition to using the check codes displayed on the wired remote controller of the indoor unit.

Use the LEDs and check codes for various checks. Details of the check codes displayed on the wired remote controller of the indoor unit are described in the Installation Manual of the indoor unit.

## Verifying current abnormal status

1. Check that DIP switch SW803 is set to OFF.
2. Jot down the states of LED800 to LED804. (Display mode 1)
3. Press SW800 for at least 1 second. The LED status changes to display mode 2.
4. Check the code whose display mode 1 equals the LED states jotted down and display mode 2 equals the current flashing status of LED800 to LED804 from the following table to identify the cause.

## Verifying an abnormal state in the past although the abnormal state no longer occurs

1. Set bit 1 of DIP switch SW803 to ON.
2. Jot down the states of LED800 to LED804. (Display mode 1)
3. Press SW800 for at least 1 second. The LED status changes to display mode 2.
4. Find an error whose display mode 1 equals the LED states jotted down and display mode 2 equals the current flashing states of LED800 to LED804 from the following table to identify the error.
  - An outside **air temperature (TO) sensor error** can be checked only while it occurs.

No.	Cause	Display mode 1					Display mode 2				
		D800	D801	D802	D803	D804	D800	D801	D802	D803	D804
1	Normal	●	●	●	●	●	●	●	●	●	●
2	Discharge (TD) sensor error	○	○	●	●	○	●	●	◎	●	●
3	Heat exchanger (TE) sensor error	○	○	●	●	○	●	◎	◎	●	●
4	Heat exchanger (TL) sensor error	○	○	●	●	○	◎	◎	◎	●	●
5	Outside air temperature (TO) sensor error	○	○	●	●	○	●	●	◎	◎	●
6	Suction (TS) sensor error	○	○	●	●	○	●	●	◎	◎	●
7	Heat sink (TH) sensor error	○	○	●	●	○	◎	●	◎	◎	●
8	Outdoor temperature sensor (TE/TS) connection error	○	○	●	●	○	◎	◎	◎	◎	●
9	Outdoor EEPROM error	○	○	●	●	○	◎	◎	◎	◎	◎
10	Compressor lock	●	●	○	●	○	◎	●	●	●	●
11	Compressor lock	●	●	○	●	○	●	◎	●	●	●
12	Current detection circuit error	●	●	○	●	○	◎	◎	●	●	●
13	Thermostat for compressor activated	●	●	○	●	○	●	●	◎	●	●
14	Model data not set (on the service P.C. board)	●	○	○	●	○	●	◎	●	◎	●
15	MCU-MCU communication error	●	○	○	●	○	◎	●	◎	◎	◎
16	Discharge temperature error	○	○	○	●	○	◎	◎	●	●	●
17	Abnormal power (open phase detected or abnormal voltage)	○	○	○	●	○	◎	●	◎	●	●
18	Heat sink overheat	○	○	○	●	○	◎	◎	◎	●	●
19	Gas leak detected	○	○	○	●	○	◎	◎	◎	◎	●
20	4-way valve reverse error	○	○	○	●	○	◎	◎	●	●	◎
21	High pressure release operation	○	○	○	●	○	●	●	◎	●	◎
22	Outdoor fan motor error	○	○	○	●	○	●	◎	◎	●	◎
23	Compressor driver short-circuit protection	○	○	○	●	○	●	◎	●	◎	◎
24	Position detection circuit error in one-line display	○	○	○	●	○	◎	●	◎	◎	◎
25	Ps sensor error	○	○	●	●	○	◎	◎	◎	●	◎
26	Ps drop down error	●	●	○	●	○	●	◎	◎	●	●

(●: OFF ○: ON ◎: Flashing)

\* The LEDs and DIP switches are located on the lower left of the P.C. board of the outdoor unit.

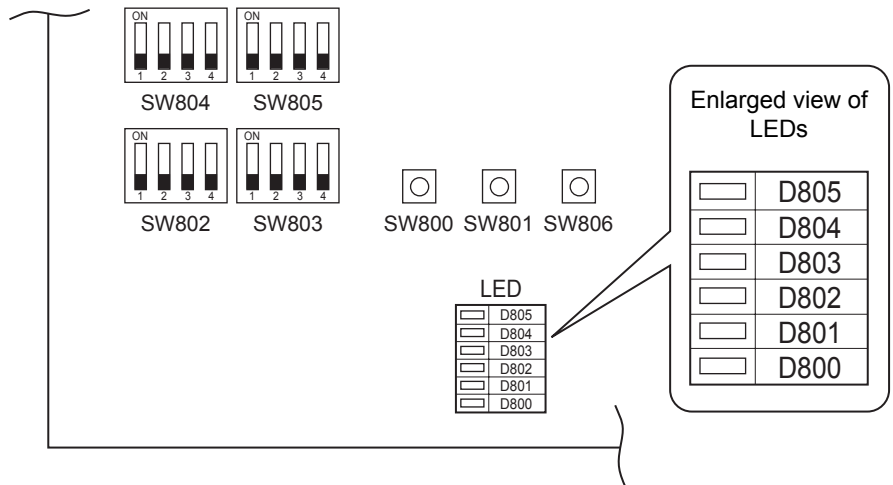

# 15 APPENDIX

## Work instructions

The existing R22 and R407C piping can be reused for our digital inverter R410A product installations.

### WARNING

Confirming the existence of scratches or dents on the existing pipes and confirming the reliability of the pipe strength are conventionally referred to the local site.

## Basic conditions needed to reuse existing pipes

Check and observe the presence of three conditions in the refrigerant piping works.

1. **Dry** (There is no moisture inside of the pipes.)
2. **Clean** (There is no dust inside of the pipes.)
3. **Tight** (There are no refrigerant leaks.)

## Restrictions for use of existing pipes

**In the following cases, the existing pipes should not be reused as they are. Clean the existing pipes or exchange them with new pipes.**

1. When a scratch or dent is heavy, be sure to use new pipes for the refrigerant piping works.
2. When the existing pipe thickness is thinner than the specified "Pipe diameter and thickness," be sure to use new pipes for the refrigerant piping works.
  - The operating pressure of R410A is high (1.6 times that of R22 and R407C). If there is a scratch or dent on the pipe or a thinner pipe is used, the pressure strength may be inadequate, which may cause the pipe to break in the worst case.

### \* Pipe diameter and thickness (mm)

Reference outside diameter (mm)	Wall thickness (mm)	Material
6.4	0.8	—
9.5	0.8	—
12.7	0.8	—
15.9	1.0	—
19.1	1.2	—
22.2	1.0	Half hard
28.6	1.0	Half hard

3. When the outdoor unit was left with the pipes disconnected, or the gas leaked from the pipes and the pipes were not repaired and refilled.
  - There is the possibility of rain water or air, including moisture, entering the pipe.
4. When refrigerant cannot be recovered
  - There is the possibility that a large quantity of dirty oil or moisture remains inside the pipes.
5. When a commercially available dryer is attached to the existing pipes
  - There is the possibility that copper green rust has been generated.

6. When the existing air conditioner is removed after refrigerant has been recovered.
  - Check if the oil is judged to be clearly different from normal oil.
    - The refrigerator oil is copper rust green in color: There is the possibility that moisture has mixed with the oil and rust has been generated inside the pipe.
    - There is discolored oil, a large quantity of residue, or a bad smell.
    - A large quantity of shiny metal dust or other wear residue can be seen in the refrigerant oil.
7. When the air conditioner has a history of the compressor failing and being replaced.
  - When discolored oil, a large quantity of residue, shiny metal dust, or other wear residue or mixture of foreign matter is observed, trouble will occur.
8. When temporary installation and removal of the air conditioner are repeated such as when leased etc.
9. If the type of refrigerator oil of the existing air conditioner is other than the following oil (Mineral oil), Suniso, Freol-S, MS (Synthetic oil), alkyl benzene (HAB, Barrel-freeze), ester series, PVE only of ether series.
  - The winding-insulation of the compressor may deteriorate.

## NOTE

The above descriptions are results have been confirmed by our company and represent our views on our air conditioners, but do not guarantee the use of the existing pipes of air conditioners that have adopted R410A in other companies.

## Branching pipe for simultaneous operation system

- In the concurrent twin system, when TOSHIBA has specified that branching pipe is to be used, it can be reused.  
 Branching pipe model name:  
 RBC-TWP30E2, RBC-TWP50E2, RBC-TRP100E  
 On the existing air conditioner for simultaneous operation system (twin, triple, double twin system), there are cases of branch pipes being used that have insufficient compressive strength.  
 In such case, please change the piping to a branch pipe for R410A.

## Curing of pipes

When removing and opening the indoor or outdoor unit for a long time, cure the pipes as follows:

- Otherwise rust may be generated when moisture or foreign matter due to condensation enters the pipes.
- The rust cannot be removed by cleaning, and new pipes are necessary.

Placement location	Term	Curing manner
Outdoors	1 month or more	Pinching
	Less than 1 month	Pinching or taping
Indoors	Every time	

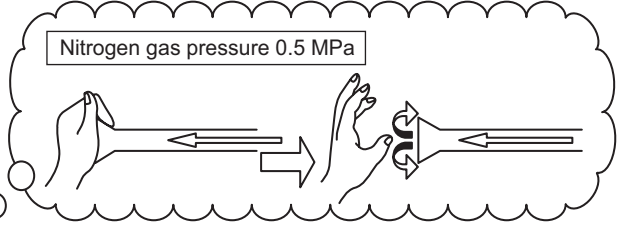
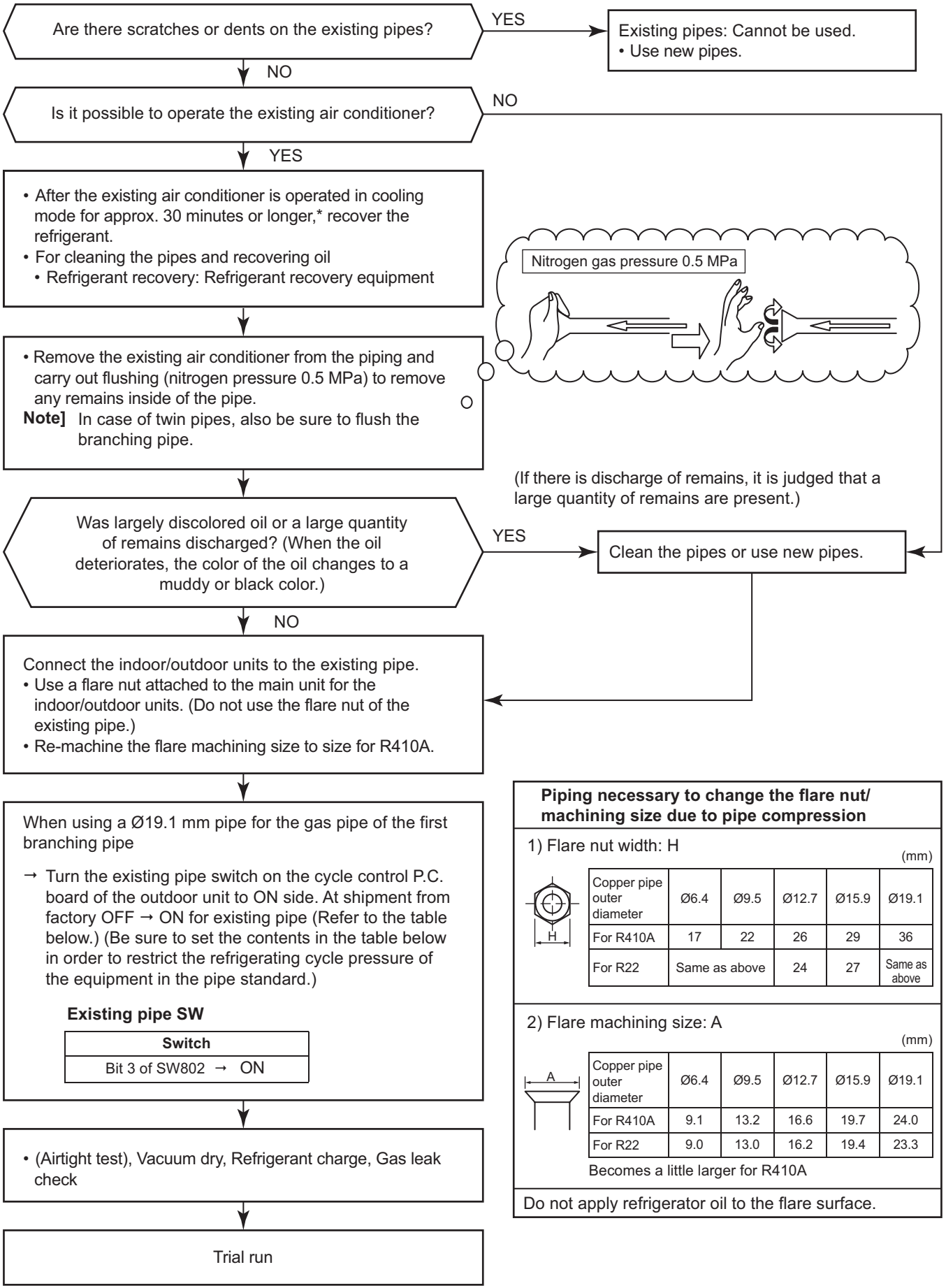

(If there is discharge of remains, it is judged that a large quantity of remains are present.)

**Piping necessary to change the flare nut/ machining size due to pipe compression**

1) Flare nut width: H (mm)

	Copper pipe outer diameter	Ø6.4	Ø9.5	Ø12.7	Ø15.9	Ø19.1
	For R410A	17	22	26	29	36
	For R22	Same as above		24	27	Same as above

2) Flare machining size: A (mm)

	Copper pipe outer diameter	Ø6.4	Ø9.5	Ø12.7	Ø15.9	Ø19.1
	For R410A	9.1	13.2	16.6	19.7	24.0
	For R22	9.0	13.0	16.2	19.4	23.3

Becomes a little larger for R410A

Do not apply refrigerator oil to the flare surface.

# WARNINGS ON REFRIGERANT LEAKAGE

## Check of Concentration Limit

The room in which the air conditioner is to be installed requires a design that in the event of refrigerant gas leaking out, its concentration will not exceed a set limit.

The refrigerant R410A which is used in the air conditioner is safe, without the toxicity or combustibility of ammonia, and is not restricted by laws to be imposed which protect the ozone layer. However, since it contains more than air, it poses the risk of suffocation if its concentration should rise excessively. Suffocation from leakage of R410A is almost non-existent. With the recent increase in the number of high concentration buildings, however, the installation of multi air conditioner systems is on the increase because of the need for effective use of floor space, individual control, energy conservation by curtailing heat and carrying power etc.

Most importantly, the multi air conditioner system is able to replenish a large amount of refrigerant compared with conventional individual air conditioners. If a single unit of the multi conditioner system is to be installed in a small room, select a suitable model and installation procedure so that if the refrigerant accidentally leaks out, its concentration does not reach the limit (and in the event of an emergency, measures can be made before injury can occur).

In a room where the concentration may exceed the limit, create an opening with adjacent rooms, or install mechanical ventilation combined with a gas leak detection device.

The concentration is as given below.

$$\frac{\text{Total amount of refrigerant (kg)}}{\text{Min. volume of the indoor unit installed room (m}^3\text{)}} \leq \text{Concentration limit (kg/m}^3\text{)}$$

The concentration limit of R410A which is used in multi air conditioners is  $0.3\text{kg/m}^3$ .

### NOTE 1 :

If there are 2 or more refrigerating systems in a single refrigerating device, the amounts of refrigerant should be as charged in each independent device.

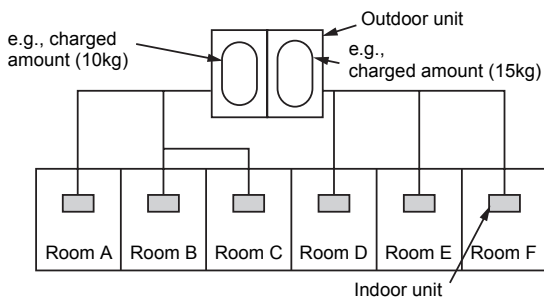

For the amount of charge in this example:

The possible amount of leaked refrigerant gas in rooms A, B and C is 10kg.

The possible amount of leaked refrigerant gas in rooms D, E and F is 15kg.

## Important

### NOTE 2 :

The standards for minimum room volume are as follows.

(1) No partition (shaded portion)

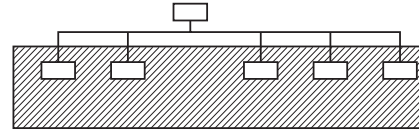

(2) When there is an effective opening with the adjacent room for ventilation of leaking refrigerant gas (opening without a door, or an opening 0.15% or larger than the respective floor spaces at the top or bottom of the door).

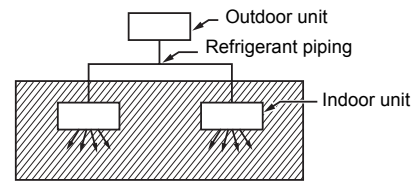

(3) If an indoor unit is installed in each partitioned room and the refrigerant piping is interconnected, the smallest room of course becomes the object. But when a mechanical ventilation is installed interlocked with a gas leakage detector in the smallest room where the density limit is exceeded, the volume of the next smallest room becomes the object.

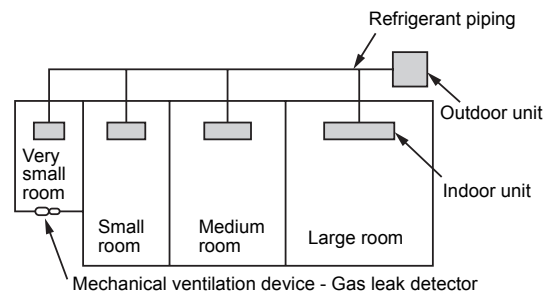

### NOTE 3 :

The minimum indoor floor area compared with the amount of refrigerant is roughly as follows:

(When the ceiling is 2.7m high)

